

INSTRUCTIONS

GLASS CHANNEL KIT

Includes Top and Bottom Channels for Floor to Ceiling Glass Walls Applications (12 linear ft.)

The kit includes the following components:

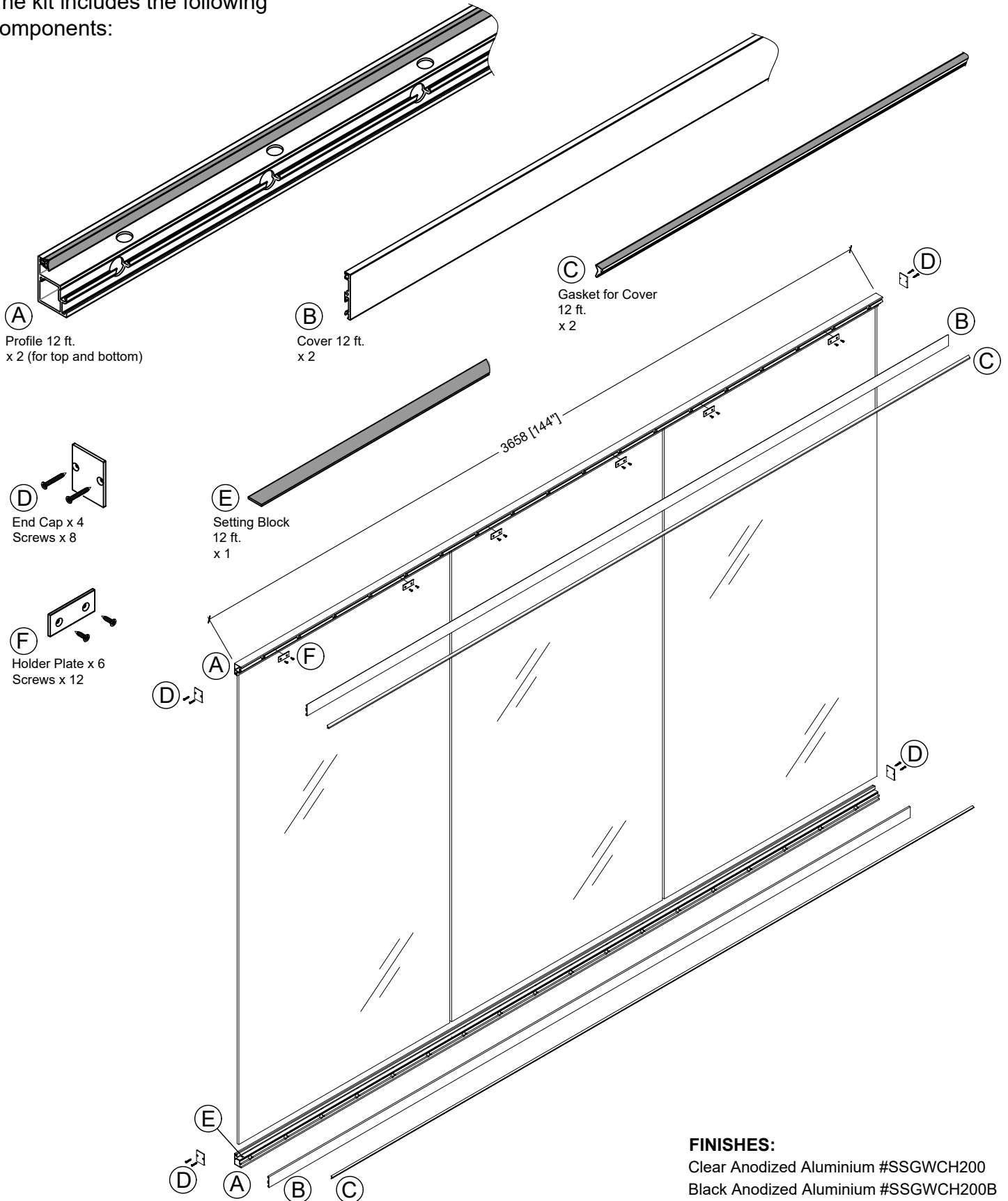

FINISHES:

Clear Anodized Aluminium #SSGWCH200
Black Anodized Aluminium #SSGWCH200B

SHEET:

1 of 2

REV.:

02.1

INSTRUCTIONS

GLASS CHANNEL KIT

Includes Top and Bottom Channels for Floor to Ceiling Glass Walls Applications (12 linear ft.)

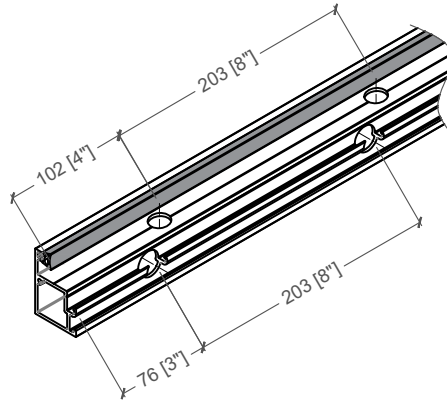
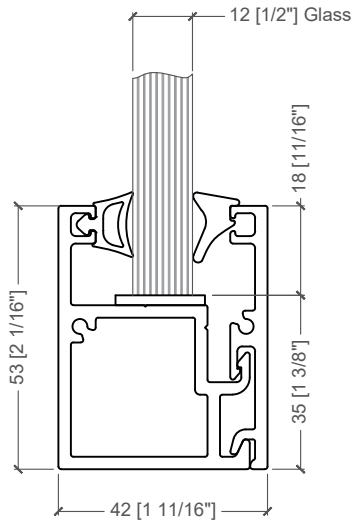

Pre-drilled access holes for fasteners with dia. $\varnothing 19$ [3/4"] suitable for surface and facial mount applications.

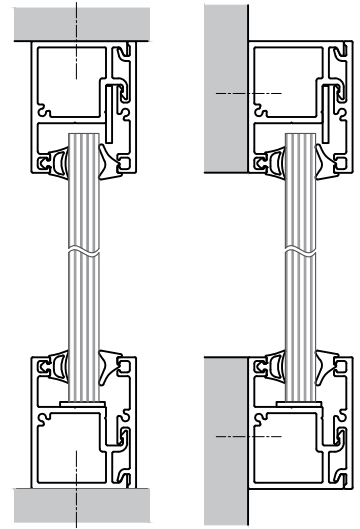

Top mount

Side mount

Installation Steps:

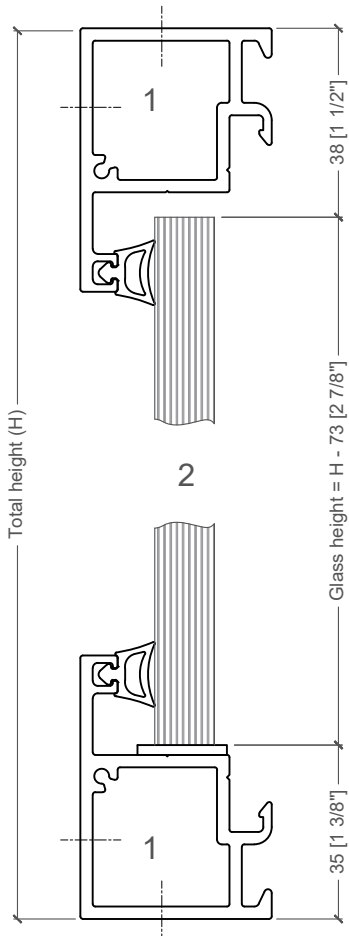

Secure the profiles from bottom or back for top or side mount applications, then install the glass panel(s).

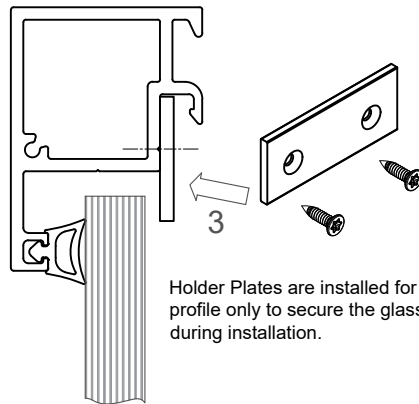

Holder Plates are installed for the top profile only to secure the glass panels during installation.

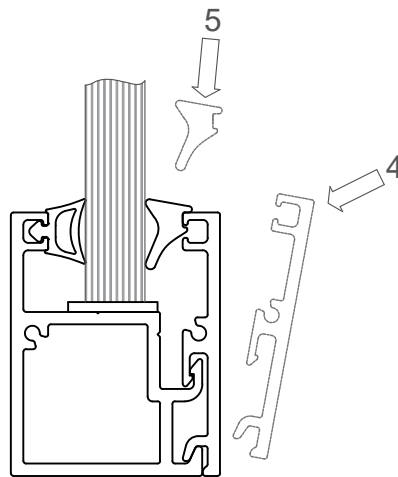

Install the Cover and the Gasket to secure the glass panel(s).

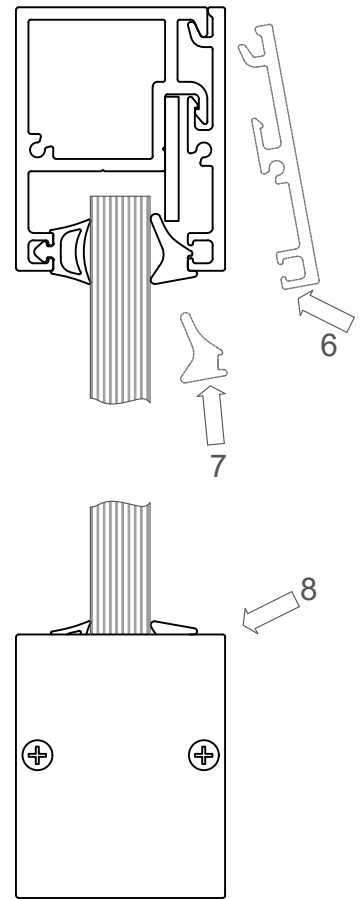

Attach the End Caps as the final step.